

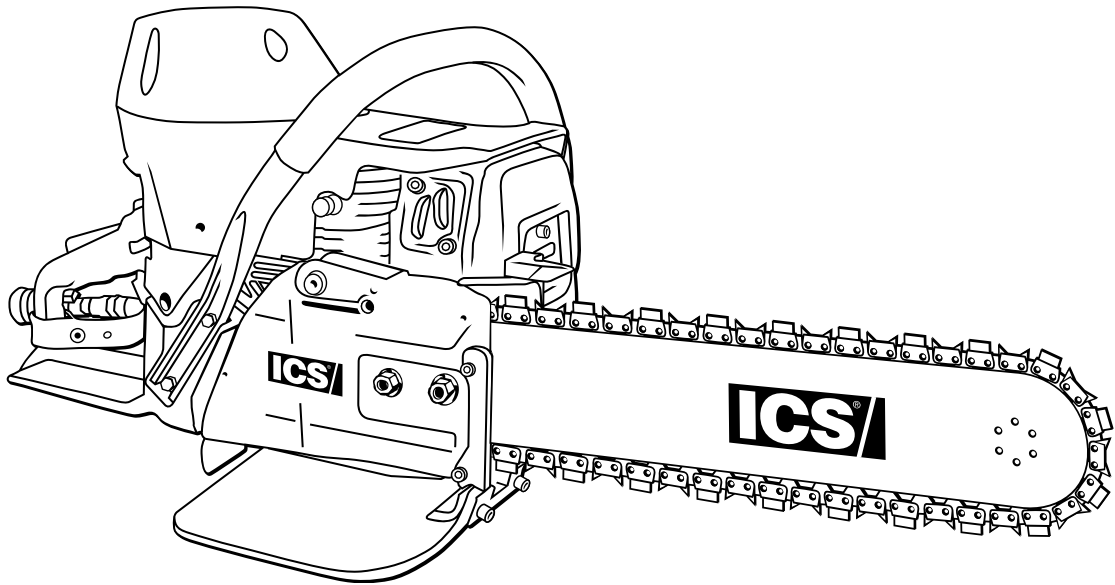

# 680GC



## OPERATOR'S MANUAL



**INTRODUCTION**

This manual outlines the maintenance and operation of ICS® manufactured products.

This is a professional tool and is solely intended for use by trained and experienced operators.

To get the maximum benefit from your saw, and ensure maximum safety, be sure to read this manual thoroughly, and periodically review safety instructions.

<b>SYMBOLS &amp; LABELS</b>	<b>4</b>
<b>SAFETY</b>	<b>5</b>
<b>TECHNICAL SPECIFICATIONS</b>	<b>8</b>
<b>SET-UP</b>	<b>9</b>
<b>OPERATION</b>	<b>12</b>
<b>MAINTENANCE</b>	<b>17</b>
<b>TROUBLESHOOTING</b>	<b>24</b>
<b>REFERENCE</b>	<b>25</b>

THE FOLLOWING SYMBOLS & DEFINITIONS ARE FOUND THROUGHOUT THIS MANUAL AND ARE DESIGNED TO MAKE YOU AWARE OF POTENTIAL HAZARDS OR UNSAFE PRACTICES.

**⚠ WARNING**

A potentially hazardous situation exists which, if not avoided, could result in death or serious injury.

**⚠ CAUTION**

A potentially hazardous situation exists which, if not avoided, may result in minor or moderate injury or property damage.

**IMPORTANT**

A potential situation exists which, if not avoided, may result in product or property damage.

THE FOLLOWING SYMBOLS & LABELS MAY BE FOUND IN THIS MANUAL OR ON THE SAW



Read the operator's manual carefully and understand the contents before you use this equipment.

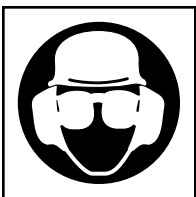

Always use:

- Protective helmet
- Ear protection
- Protective glasses or full face protection



Wear hand protection



THE FOLLOWING SYMBOL APPLIES TO ALL THE ITEMS LISTED ON THIS PAGE



A potentially hazardous situation exists which, if not avoided, could result in death or serious injury.

Diamond chain breakage can result in high-speed ejection of parts, which can result in death or serious personal injury to operators or bystanders. The items listed below are critical to minimizing the risk of diamond chain breakage and injury.

- **DO NOT** operate a diamond chainsaw with a damaged, modified, broken, or missing side cover, bottom guard, or guard flap. The side cover, bottom guard, and guard flap provides protection against contact with moving parts, ejected debris, broken diamond chain, thrown water and concrete slurry.
- **DO NOT** operate a saw with loose, missing, damaged or improperly repaired parts.
- **DO NOT** insert a chain-based cut-off saw into a slot narrower than the diamond chain segments. Rapid pushback might occur. Reference: Most diamond segments are .225 inches (5.72 mm) wide.
- **DO NOT** use damaged, modified or improperly repaired diamond chain.
- **DO NOT** run a chain-based cut-off saw upside-down. Concrete debris can fly back into the operator's face.
- **DO NOT** cut ductile iron pipe with a chain-based cut-off saw. Segment loss or diamond chain breakage may occur.

## THE FOLLOWING SYMBOL APPLIES TO ALL ITEMS LISTED ON THIS PAGE

 **CAUTION**

A potentially hazardous situation exists which, if not avoided, may result in minor or moderate injury or property damage.

- Always turn a chain-based cut-off saw OFF when performing maintenance on the saw including diamond chain tensioning.
- Never use equipment that is not functioning properly. Have the cut-off saw repaired by qualified service personnel.
- Turn engine OFF before refueling. Keep away from open flame. Always provide adequate ventilation when handling fuel. Move chain-based cut-off saw at least 10 feet (3 m) away from refueling area before starting.
- SealPro® diamond chains require a minimum water pressure of 20 psi (1.5 bar). Insufficient water supply may result in excessive wear to the diamond chain, which can lead to loss of strength and diamond chain breakage.
- Never start a chain-based cut-off saw unless the guide bar, diamond chain and side cover are properly installed.

**GENERAL SAFETY PRECAUTIONS**

- Always wear protective clothing, including hard hat, eye protection, hearing protection, and gloves.
- Avoid loose fitting clothing.
- Perform safety checks before starting each day.
- Always operate tool with solid footing and with both hands on cut-off saw.
- Remove or control slurry to prevent slippery conditions while cutting.
- Be sure there are no obstructions (plumbing, electrical conduit, air ducts) and no unnecessary people present.
- Set up a well-marked safety zone with a roped boundary and clear signs.
- Provide adequate ventilation when working in an enclosed area. Breathing exhaust gases is dangerous.
- To avoid electrocution, check for live electrical wiring near cutting area.

THE FOLLOWING SYMBOL APPLIES TO ALL ITEMS LISTED ON THIS PAGE

**IMPORTANT**

A potential situation exists which, if not avoided, may result in product or property damage.

**Note:** The chain-based cut-off saw is equipped with a two-stroke engine and must always be run using a mixture of gasoline and ICS<sup>®</sup> two-stroke engine oil. It is important to accurately measure the amount of oil to be mixed to ensure that correct mixture is obtained. When mixing small amounts of fuel, even small inaccuracies can drastically affect the ratio of the mixture.

- This engine is designed to be operated on premium unleaded gasoline.
- Use high quality, unleaded gasoline with a minimum octane rating of 90. If lower octane gasoline is used, engine temperature will increase which will result in a piston seizure and damage to the engine.
- Fuel mixture: 25:1 gasoline/oil mixture. Incorrect fuel mixture is the number one cause of piston seizure.
- Use ICS<sup>®</sup> brand two-stroke engine oil.
- Never use two-stroke oil formulated for water-cooled two-cycle engines, such as outboard motor oil.
- Never use motor oil intended for four-stroke engines.
- Use of water is required to cool bar and chain during break-in period.

**ENGINE BREAK-IN**

- It is very important to break-in a new engine to “seat” all moving parts, especially the piston rings.
- To break-in the engine, run one full tank of 25:1 fuel at idle, cycling the throttle every 5 to 10 minutes to prevent loading.
- Failure to break-in an engine may result in piston seizure.
- Failure to break-in an engine at altitude will result in 50% loss of power output for the first hour of operation making the initial cutting experience unsatisfactory.
- Proper chain tension, especially for first cut, is extremely important. Over-tensioning of bar and chain, especially at altitude, could result in severe loss of power output making initial cutting experience unsatisfactory.

Engine Type	2-stroke Single Cylinder Air Cooled
Displacement	4.9 cu-in (80cc)
Horsepower	5.7 HP (4.2 kw) @ 9,000 RPM
Torque	37.2 in-lbs (4.2 Nm)
Engine Speed	11,500 +/- 500 rpm 2,800-3,200 rpm idle
Diamond Chain Speed	In cut = 4,000 sfm No load = 5,300 sfm
Weight	21 lbs (9.5 kg) with guide bar and diamond chain
Cut Depth	Up to 12 inches (30.5cm) 10 inches square (25.4cm)
Dimensions	18 inches (46cm) length 11.5 inches (29cm) height 10 inches (25cm) width
Air Filter	Dry nylon
Carburetor	Walbro WJ85B, throttle shaft sealed, pressure compensating
Starter	Dust and water shielded
Ignition	Special water resistant electronic ignition
Clutch	Three-weight, single spring
Fuel ratio	25:1 gasoline-to-oil
Fuel Capacity	0.23 gal (.88 liter) 15-18 minutes run time per tank
Water Supply	Minimum 20psi (1.5 bar)
Noise Level	101dB at 3 ft (1m)
Vibration Level	10.5 m/s <sup>2</sup> (front handle)
Engine Break-in Period	One tank, without cutting, cycling throttle
Spark Plug	NGK BPMR8Y



## GUIDE BAR AND DIAMOND CHAIN INSTALLATION

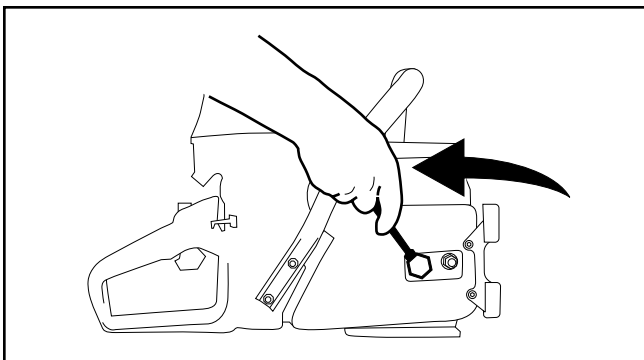

**STEP 1**  
Loosen side cover nuts and remove side cover.

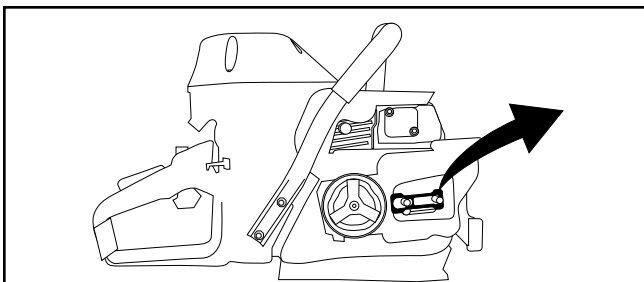

**STEP 2**  
Remove shipping spacer.

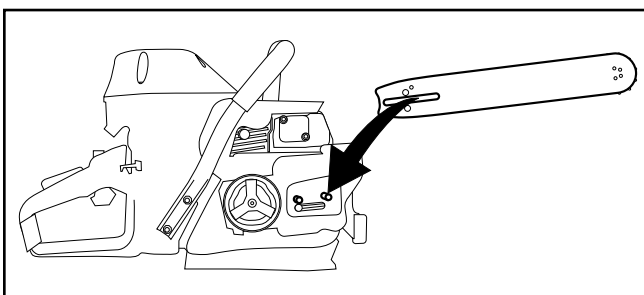

**STEP 3**  
Place bar onto studs and chain adjustment pin.

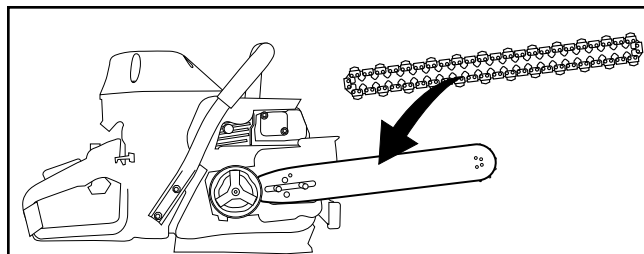

**STEP 4**  
Mount the diamond chain on the guide bar starting at the drive sprocket and continue over the guide bar nose.

Install the diamond chain correctly.  
If using a single bumper chain, the bumper must always lead the segment into the cut as shown here.

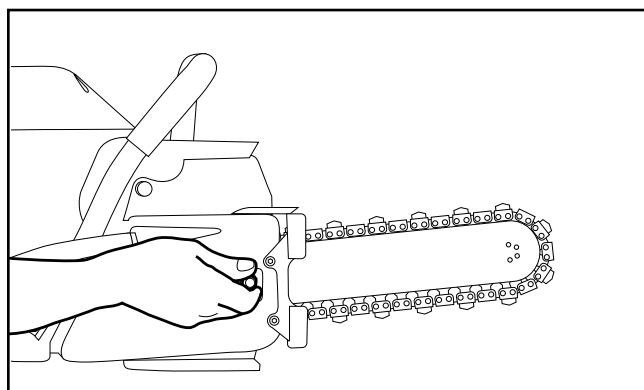
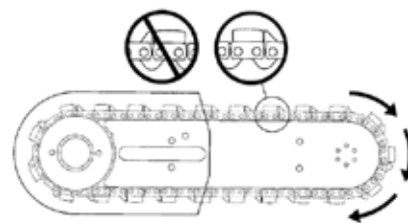

**STEP 5**  
Install the side cover.

## GUIDE BAR AND DIAMOND CHAIN INSTALLATION

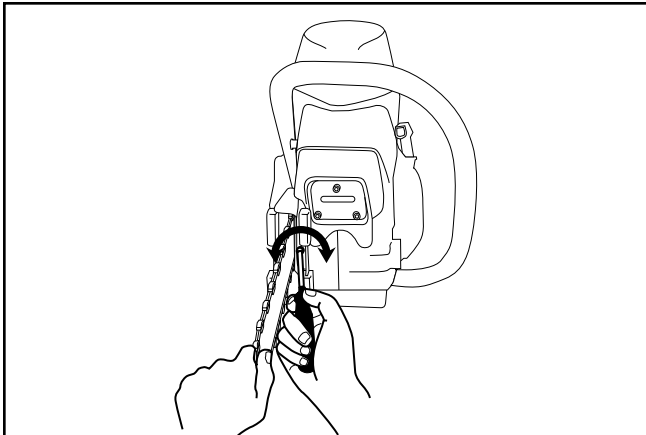
**STEP 6**

Make sure all the drive links are inside the guide bar groove then lift the bar nose and tension the chain by turning the screw clockwise.

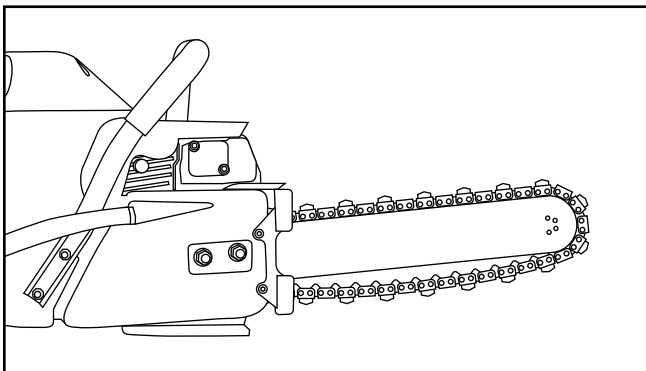
**STEP 7**

If the chain is too loose, it could come off the bar, or it will allow the drive sprocket to spin without turning the chain, which can chew up the chain drive links. If the chain is too tight, a lot of the saw's power goes into turning the chain rather than into the cut. In extreme over-tightened cases, the saw may not be able to turn the chain at all. In addition, damage can occur to the bar nose and premature stretch may occur. See Note 1.

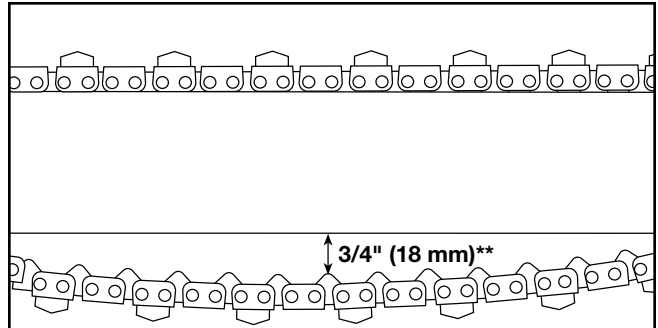

**\*\* As measured without pulling downward (eg. hanging by gravity)**

**STEP 8**

All chains have a tendency to stretch when used. Diamond chains stretch more than wood cutting chains because of the abrasive materials they are cutting. When a chain stretches to a point where the drive links are hanging approximately 1/2" (12 mm) to 3/4" (18 mm)\*\* below the bar, it's time to tension the chain. See Note 2.

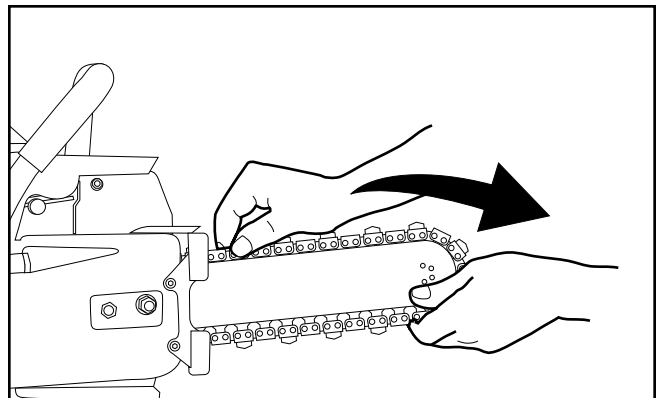
**STEP 9**

Before cutting, check for proper tension by pulling the chain around the bar by hand. If you cannot easily pull by hand, the chain is too tight and needs to be loosened a little. See Note 3.

## GUIDE BAR AND DIAMOND CHAIN INSTALLATION

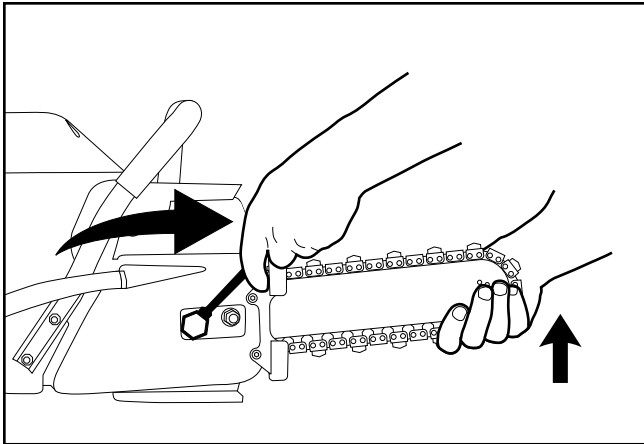
**STEP 10**

Continue to lift up on the nose of the guide bar and firmly tighten the side cover nuts.  
**NOTE:** To prevent chain tensioner breakage, be sure the side cover nuts are tightened to approximately 20 ft-lbs (27 Nm).

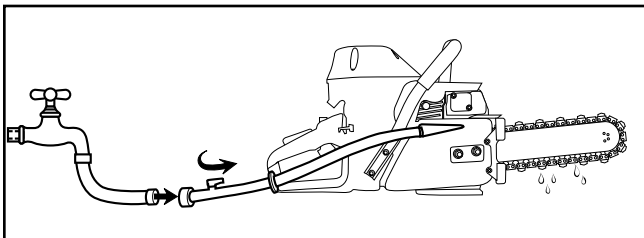
**STEP 11**

Attach to water source with pressure of not less than 20 psi (1.5 bar).

**Note 1:** Be aware that the guide bar rails may develop sharp edges over time so always pull the diamond chain by the diamond segments.

**Note 2:** Do not “over tension” the diamond chain. Loss of power will result. It is normal for the driveline to hang underneath the guide bar. The diamond chain should be tight but be able to be pulled around the guide bar by hand.

**Note 3:** To prevent chain tensioner breakage, be sure the side cover nuts are tightened to approximately 20 ft-lbs (27Nm).

## FUEL HANDLING

**⚠ CAUTION****FUEL MIXTURE: 25:1 gasoline/oil mixture.**

GASOLINE	OIL
US Gallon	US Fl oz
1	5.2
2 1/2	12.8
5	25.6

GASOLINE	OIL
Liters	ml
1	40
5	200
10	400
20	800

- Use premium unleaded gasoline with a minimum octane rating of 90. If lower octane gasoline is used, engine temperature will increase which can result in a piston seizure and damage to the engine.
- Always provide adequate ventilation when handling fuel.
- Use caution when handling gasoline. Avoid direct contact with skin or inhaling fuel vapor.

## FUEL MIXING

- Always mix gasoline and oil in a clean container intended for use with fuel.
- Keep fuel container closed tightly to prevent moisture from getting into the fuel.
- Always begin mixing fuel by adding half the amount of gasoline to be used. Then add the correct amount of two-stroke oil for 25:1 mixture and finish filling the container with gasoline.
- Do not mix more than one month's supply of fuel. This helps prevent the separation of the two-stroke oil from the gasoline (varnishing).
- If the cut-off saw is not used for an extended period of time (3 months) the fuel tank should be emptied and cleaned.

## FUELING

- Always shut off the cut-off saw before fueling.
- Before fueling, clean the area around fuel cap to prevent dirt from contaminating the fuel. Contamination of the fuel tank can lead to cut-off saw malfunction.
- Thoroughly mix the fuel in it's container before fueling.
- Slowly open the fuel cap to release any pressure that may have built-up in the tank.
- After adding fuel, carefully install the fuel cap and tighten firmly by hand.

## STARTING AND STOPPING A CHAIN-BASED CUT-OFF SAW

**⚠ WARNING**

Never start a chain-based cut-off saw without the guide bar, diamond chain and side cover properly assembled. The clutch may come loose and cause personal injury.

**⚠ CAUTION**

Always move a chain-based cut-off saw at least 10 feet (3 m) away from the fueling area before starting.

**IMPORTANT**

Place the chain-based cut-off saw on clear ground. Ensure that secure footing is established and diamond chain is not contacting any objects.

## COLD ENGINE STARTING PROCEDURE

1. Toggle the ignition switch to the "ON" position and pull the choke lever out.
2. Lock the throttle in the start position by depressing the trigger (A) and trigger interlock (B) at the same time.
3. Depress and hold throttle lock button (C) while releasing the trigger and trigger interlock in succession.
4. Press decompression valve (D).
5. Open the water valve 1/4 turn.
6. Place the 680GC Cut-Off Saw on the ground making sure the chain is free of any obstructions.
7. Place right foot on the base of the rear handle.
8. Place left hand on front handle.
9. With right hand, slowly pull starter handle until the starter pawls engage.
10. Pull the starter cord (*hard, fast, short pulls*) until engine fires or "pops" - should be 1 to 7 pulls.
11. Push the choke lever in.
12. Check decompression valve. Press if necessary.
13. Pull the starter cord until engine starts - should be 1 to 2 pulls.
14. When the engine starts, allow the engine to idle. Pull on the throttle trigger several times to help warm up the engine.
15. Open the water valve completely.

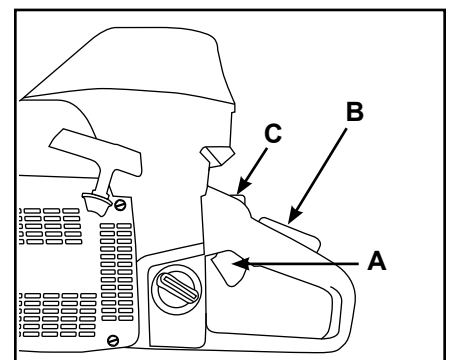

Figure 1: a-Trigger, b-trigger interlock, c-throttle lock

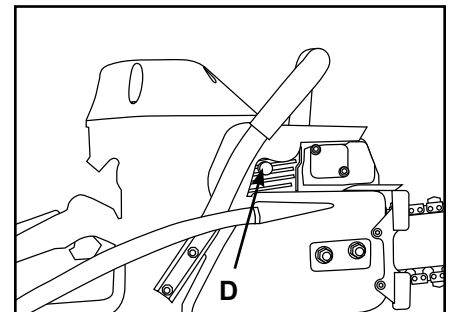

Figure 2: Decompression valve

## WARM ENGINE STARTING PROCEDURE

1. Use the same procedure as starting cold engine, but **DO NOT pull choke lever out**. If choke is used, the carburetor will flood with gas.
2. If the engine does not start in 3 hard, fast pulls with the throttle locked, unlock the throttle and pull the starter cord 3 more times.

Note: To hold the trigger fully open it may be necessary to insert right foot into rear handle opening and twist.

## PRE-CUT CHECKLIST

- Proper Diamond Chain Installation: The bumper should lead the segment into the cut.
- Proper Diamond Chain Tension: The diamond chain should be tight but easily pulled around the guide bar by hand.
- Ensure all safety devices are properly mounted and functional and that all controls are in proper working order.
- Be sure there are no obstructions (plumbing, electrical conduit, air ducts) and no unnecessary people present.
- Always wear protective clothing, including hard hat, eye protection, hearing protection, non-slip safety boots, and gloves. Avoid wearing loose fitting clothing.
- Diamond chains with SealPro® require a minimum water pressure of 20 psi (1.5 bar).



## PLANNING THE CUT

- Outline the cut with a permanent marker for a visual cutting guide.
- Avoid pinching the guide bar and diamond chain. Always cut the bottom of an opening first, then top, and then the sides. Save the easiest cut for last.
- For the straightest cuts use the "Step Cut" method. First score the entire cut line approximately a half-inch deep using the nose of the guide bar. Next, deepen the cut by about two inches. Then plunge all the way through and complete the cut using the Wallwalker®.
- Be sure cut concrete cannot fall and injure operator or bystanders. Concrete is very heavy, one cubic foot = 12"x12"x12" = 150 lbs. (30cm x 30cm x 30cm = 68kg).
- Check for live electrical wiring near the cutting area or in the concrete to avoid electrocution.

## CUTTING WITH THE 680GC CUT-OFF SAW

To start a cut, hold trigger on full throttle and slowly plunge the nose of the guide bar straight into the wall. Lengthen the cut and engage the point of the fixed Wallwalker®. Use the fixed Wallwalker® as a pivot point and pull up on the rear handle to rotate the guide bar into the cut.

## CUTTING TIPS

- Always operate the chain-based cut-off saw at full throttle. Apply enough feed force so that the free running RPM drops 20 to 30%. If too much force is applied, the cut-off saw will lug or stall. The diamond chain will not have enough speed to cut effectively. If too little feed force is applied, the diamonds will skid and glaze over.
- For straighter cuts use the “step cut” method. First score the entire cut line with the nose of the guide bar approximately 1/2 inch (12mm) to 1 inch (25mm) deep. Next, deepen the cut by about 2 inches (50 mm). This groove will help guide the guide bar for a straight cut. Then plunge all the way through and complete the cut using the fixed Wallwalker®.
- Plunge cut instead of starting at the top of the wall. This will reduce chatter, extend diamond life, create a straighter cut and more quickly enable the use of the Wallwalker®.
- Use the fixed Wallwalker® to help cut more efficiently and reduce operator fatigue. The fixed Wallwalker® is a fulcrum that can be used to apply additional force when cutting. To use correctly, plunge into the wall and simply engage the point of the fixed Wallwalker® into the cut and pry upward with the rear handle.
- As the cut-off saw begins to rotate up, feed force is developed down the line of the intended cut. Once the cut-off saw is fully rotated upwards, pull the cut-off saw out of the cut a few inches and re-engage the pick into the cut and repeat.
- When cutting heavy rebar, slowly “rock” the cut-off saw so that you’re always cutting concrete as well as steel. This will help keep the diamonds exposed. Also, expect less diamond chain life when cutting heavy rebar.
- Expect more diamond chain stretch when making nose buried cuts for extended periods of time, as the diamond chain does not have a chance to “throw” the slurry away from the nose of the guide bar.
- If the cut-off saw begins to cut consistently crooked, turn the guide bar over and use the other side. Dress worn rails with belt sander. Note: The normal life of a guide bar is 2 to 3 diamond chains. Heavy rebar can shorten guide bar life.
- When using a new diamond chain, you can increase the cutting speed by “opening up the diamonds”. Make a few cuts in an abrasive material such as a cinder block.

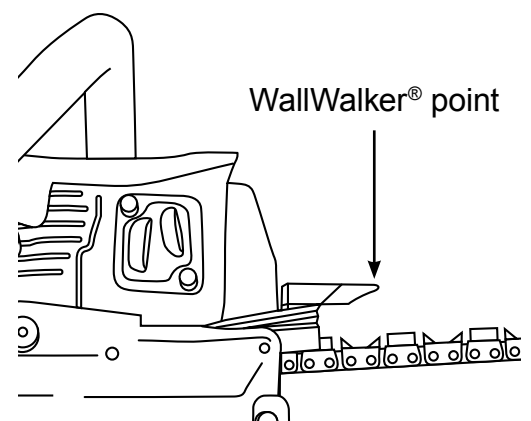

**SYSTEM CLEAN-UP**

- After cutting, run the saw for at least 15 seconds with the water on to flush slurry and debris from diamond chain, guide bar and drive sprocket.
- Wash concrete slurry from cut-off saw assembly.
- Avoid getting any water in the carburetor or exhaust system. If water enters exhaust port, point the guide bar tip down and pull the starter handle several times to expel water from muffler.
- Remove guide bar and diamond chain. Flush out the chain tensioner with high water pressure and lubricate with grease.
- After cleaning the cut-off saw, spray the entire saw body, diamond chain, guide bar, and drive sprocket with lightweight oil. Using lightweight oil on the cut-off saw will minimize rust and help reduce slurry build up.



Follow these simple maintenance guidelines  
and the 680GC Cut-Off Saw will keep running at its very best.

### AFTER EACH USE

1. Rinse the saw, guide bar and diamond chain with water.
2. Follow instructions on the Daily Maintenance Label, located on the air filter cover.

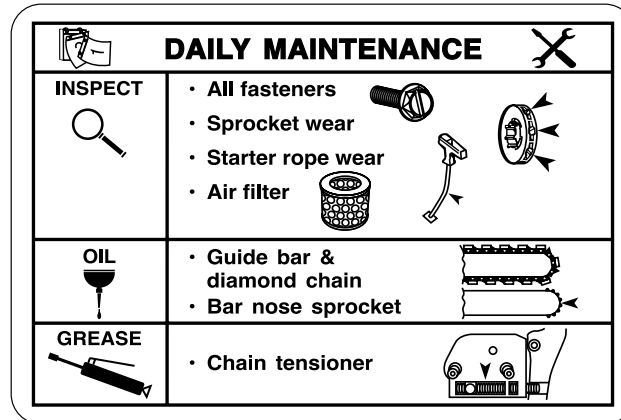

3. Inspect and tighten all fasteners as necessary.
4. Inspect drive sprocket for tooth wear and replace if tooth tips are pointed.
5. Inspect the starter cord. Replace if frayed.
6. Clean air filter. Inspect the air filter for holes. Replace as necessary.
7. Spray saw, guide bar, and chain with lightweight oil.
8. Grease the chain tensioner.

### AFTER 10 HOURS OF USE

1. Remove the starter cover and lubricate the starter recoil spring. Clean the flywheel fins and the starter pawls with a wire brush, then grease the starter pawls.
2. Remove the spark plug and clean with a wire brush. Check the electrode gap. The correct gap is 0.020 inches (0.5mm).

### AFTER 40 HOURS OF USE

1. Change the spark plug. Adjust the electrode to 0.020 inches (0.5mm).
2. Check the fuel filter located inside the fuel tank. Clean or replace if clogged.

**AIR FILTER**

**IMPORTANT**

The air filter is made from a nylon micro mesh air filter and an internal spit-back screen. Both must be kept clean for the engine to operate properly. If the saw is not reaching full RPM, most likely one or both of the air filters are dirty.

- The air filter (Figure 1) should be free of holes and white in color.
- Replace air filter when dirty.
- The spit-back screen (Figure 2) should be free of holes and be white in color. Clean with mild solvent or gasoline and dry with high pressure air. If spit-back screen is dirty the saw will not reach full RPM.
- During re-assembly, tighten air filter wing-nut "finger tight" plus an 1/8" of a turn with wrench.

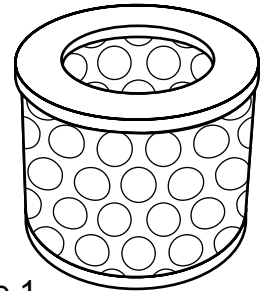

Figure 1



Figure 2

**STARTER HOUSING ASSEMBLY**

**IMPORTANT**

It is common for concrete slurry to get inside the starter housing assembly during cutting. This can cause the starter pawls to stick and not engage when the rope is pulled.

- After each usage, thoroughly flush the starter housing assembly with water. (Figure 3)
- Lubricate the starter pawls by spraying light weight oil into the starter housing through the vents. (Figure 3)
- Check the starter cord for fraying, replace if necessary.

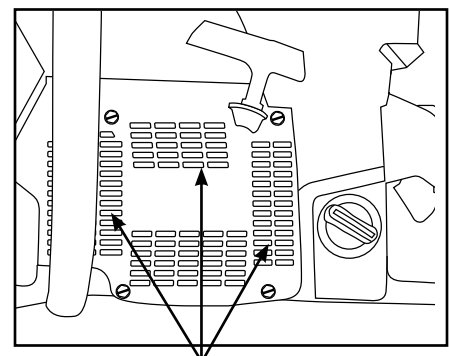

Figure 3

## STARTER CORD REPLACEMENT

- Remove the 4 screws that attach the starter assembly to the crankcase.
- Pull the cord out approximately 8" and lift the cord up into the notch in the pulley (Figure 1). Relax the recoil spring by placing thumb on pulley and gently allow the pulley to unwind entirely. Undo the screw in the center of the pulley and remove the pulley.
- Thread the new cord through the starter cover and fasten it to the pulley. Wind 4 turns of the starter cord on to the pulley. Assemble the starter pulley against the recoil spring so the end of the spring engages into the backside of the pulley. Install the retaining screw in the center of the pulley.

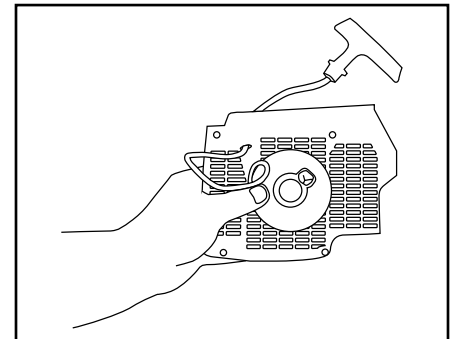

Figure 1

## TENSIONING THE RECOIL SPRING

- Lift the starter cord up into the notch on the starter pulley (Figure 3) and wind the pulley clockwise 5 full turns. Remove the cord from the pulley notch while pinching the pulley. Release the pulley slowly allowing it to wind the rope counterclockwise onto the pulley.
- When completed, the starter handle should be pulled back in the starter housing under it's own tension.
- To check that the starter pulley was assembled correctly, pull the cord completely out of the housing, grip the pulley and turn clockwise another 1/2 turn. If the pulley turns another 1/2 turn it is correctly assembled.

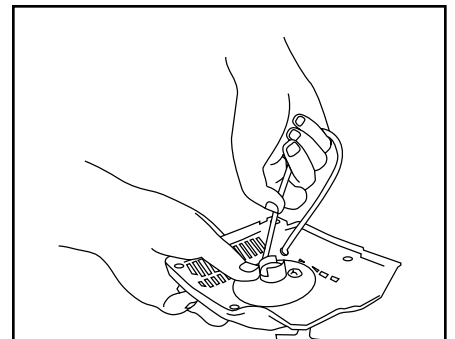

Figure 2

## STARTER HOUSING ASSEMBLY

- To reattach the starter housing, first pull the starter cord out, then hold the starter housing against the crankcase (Figure 3). Slowly release the starter cord to enable the pulley to fit between the pawls.
- Insert and tighten the screws. Use blue Loctite® #242.

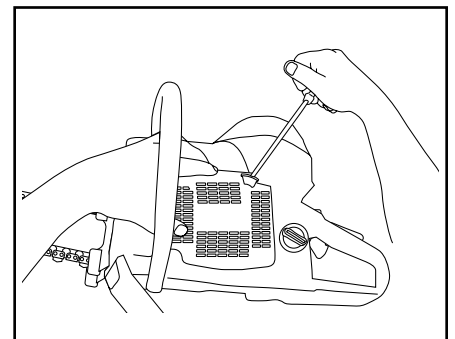

Figure 3

**CHAIN TENSIONER**

**IMPORTANT**

The chain tensioner (Figure 1) can become clogged with concrete slurry during cutting. After each use thoroughly flush the chain tensioner with water and apply a liberal amount of grease.

**Most Common Causes of Tensioner Damage:**

- Side cover nuts are not tight enough. Side cover nuts should be torqued to 20 ft-lbs (27Nm).
- Chain tensioning is attempted without loosening the side cover nuts.
- Concrete debris in tensioner pocket.

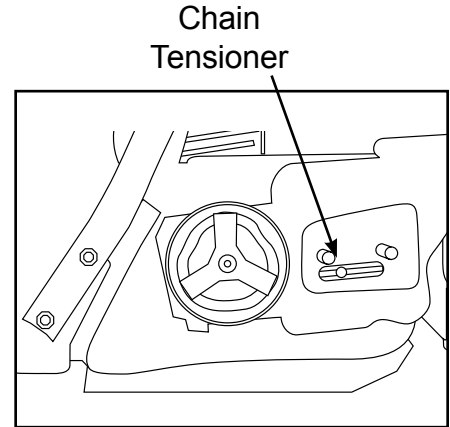

Figure 1

**DRIVE SPROCKET**

**IMPORTANT**

The drive sprocket (rim sprocket) is a wear item and should be replaced every 2-3 diamond chains.

**IMPORTANT**

The needle bearing inside the splined adapter should be greased regularly and should be replaced with each new clutch cup.

A rim sprocket system (Figure 2) consists of a clutch cup w/ splined adapter and a rim sprocket. When the rim sprocket wears out, it is the only part that needs to be replaced. The clutch cup with splined adapter is a wear item that needs replacement after 3 to 5 rim sprockets have been used.

- Inspect the rim sprocket for wear. Replace the rim sprocket if the drive teeth become pointed.
- Check the drive sprocket bearing by spinning clutch cup. Replace the bearing if it is worn out.
- The needle bearing on the drive shaft must be greased regularly, use high quality water-resistant bearing grease.

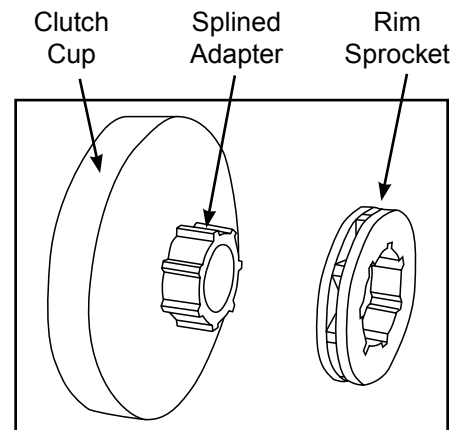

Figure 2

## DRIVE SPROCKET REMOVAL

- Remove the side cover, guide bar, diamond chain, and clutch slurry shield.
- Remove the spark plug and insert the piston stop (supplied with each saw) into the spark plug hole. Pull the starter cord slowly until the piston stops. (Figure 1) Use a 19mm wrench to turn the clutch clockwise and remove.
- Slide the clutch cup/drive sprocket assembly off the shaft. Remove the needle bearing and inspect for heavy wear or damage.

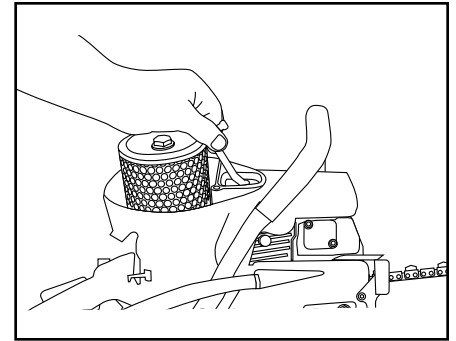

Figure 1

## DRIVE SPROCKET INSTALLATION

- Slide the rim sprocket onto the splined adapter, either side out.
- Apply a liberal amount of grease to the needle bearing.
- Place the thin metal washer onto drive shaft. Slide the needle bearing and clutch cup w/rim sprocket onto shaft (Figure 2).
- Install the clutch by turning it counter clockwise on the drive shaft and firmly tighten. Replace the clutch slurry shield. Installation of drive sprocket assembly is now complete.

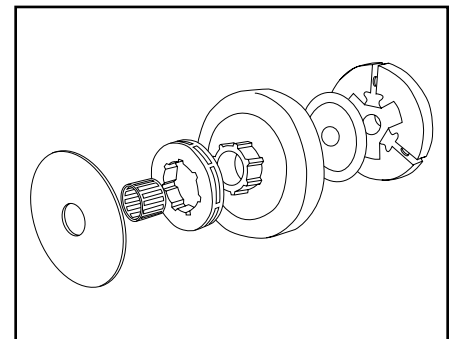

Figure 2

**SPARK PLUG**

- A worn or fouled spark plug can cause a loss of power, difficulty starting or rough idle (Figure 1).
- If the spark plug is dirty, clean it with a wire brush and check the electrode gap. Readjust if necessary. The correct gap is .020" (0.50mm).
- The spark plug should be replaced after 40 hours of operation or earlier if the electrode is badly corroded.
- Always use the recommended spark plug type. Using the wrong spark plug can severely damage the piston and cylinder (NGK BPMR8Y).

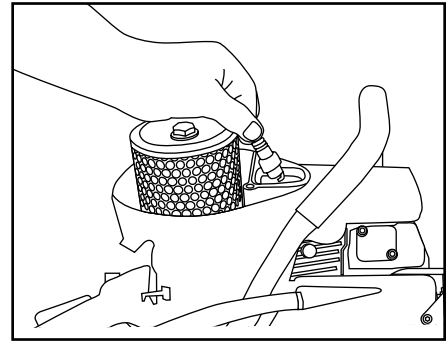

Figure 1

**CARBURETOR**

- The function of the carburetor is to mix fuel with air. Adjustments other than idle speed should be made by a servicing dealer.
- **Before adjusting the engine idle speed, make sure the air filter is clean and the engine is warmed up.**
- **T – Idle Screw** (Figure 2) is adjusted so that the engine idles smoothly but the clutch does not engage.
- **If cut-off saw has been running satisfactorily and there is a gradual decrease in power and drop in RPM at full throttle, the filter may have become dirty or saturated with water.**

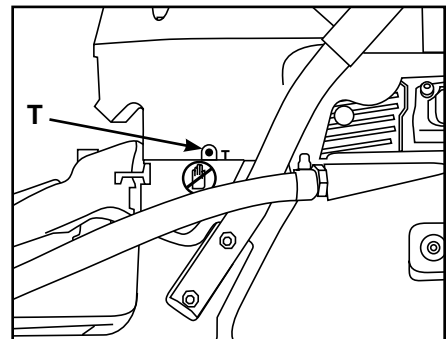

Figure 2

## GUIDE BARS

- The guide bar is designed to be used on both sides. If the cut is consistently leading to one side, turn the guide bar over to expose a new set of guide rails.
- A table mounted belt or disc sander can be used to square the rails of a worn guide bar. A badly worn guide bar can quickly damage an expensive diamond chain. If the diamond chain is touching the bottom of the guide bar groove, replace the guide bar.
- Check the guide bar for straightness. Minor adjustments can be made by bending the guide bar slightly.
- Proper diamond chain tension will extend guide bar life. See page 9.
- Under some circumstances, especially low water pressure, the sprocket nose can wear out before the guide bar body. Sprocket nose replacement kits may be purchased from an Authorized Dealer (part #70249).
- Spray the diamond chain and guide bar with lightweight oil for storage.
- Store guide bar with the sprocket nose up.
- Periodically clean the water ports inside the groove of the guide bar using a small diameter piece of wire.
- The guide bar is solely a guide track for the diamond chain. Never use the guide bar to lift, twist or pry concrete material.

## TROUBLESHOOTING

- **CUT-OFF SAW WON'T REACH FULL RPM** – Air filter or pre filter may be dirty.
- **SLOW DIAMOND CHAIN SPEED** – Diamond chain tension too tight. Diamond chain should always be able to be pulled around the guide bar by hand. It is normal for the diamond chain drive links to hang below the guide bar.
- **POOR CUTTING SPEED** – Diamonds may be “glazed over”. Make a few cuts in an abrasive material such as a cinder block to expose the diamonds.
- **CHAIN TENSIONER BREAKAGE** – Side cover nuts are not tight enough. Torque to 20 ft-lbs (27Nm).
- **WATER NOT FLOWING** – Water hose is kinked or supply is not turned on.
- **WON'T START** – Turn ignition switch on or possible defective spark plug.
- **WON'T START** – Low compression, less than 120 psi (8 bar). Possible incorrect fuel mixture.  
Reference: new = 150 to 180 psi (10 to 12 bar)  
used = 140 to 160 psi (9 to 11 bar)
- **DIFFICULT TO START** – Possible flooded engine. Turn ignition switch on, push choke in, hold throttle on full with foot and pull starter cord until engine starts.
- **DIFFICULT TO START** – Possible fouled spark plug. Remove spark plug, clean with wire brush and re-gap.
- **DIAMOND CHAIN BREAKAGE** – Diamond chain installed backwards. Bumpers should lead segments into the cut.
- **DIAMOND CHAIN BREAKAGE** – Not enough feed pressure while cutting. Avoid letting the cut-off saw bounce and chatter.

**Further questions?**

**Call 1-800-321-1240 or  
visit our website at [icsbestway.com](http://icsbestway.com)**



## APPROXIMATE CUTTING RATES

Material	Cutting Rate
Hard aggregate & Steel	15-25 sq-in/min (90-160 sq-cm/min)
Medium aggregates	20-30 sq-in/min (160-190 sq-cm/min)
Masonry, Soft aggregates	30-50 sq-in/min (190-320 sq-cm/min)

## INCH-FOOT DEFINITION

An in-ft is a measure of how much material is to be cut.

An in-ft is defined as: depth in inches times length in feet.

Note: 129 in-ft = 1m<sup>2</sup>

Example: How many in-ft are in this doorway?

1. Determine the depth of the cut in inches.  
For this example, 8 inches.
2. Determine the length of the cut in feet.  
 $3+7+3+7=20$  feet
3. Multiply the two numbers  
 $8 \text{ in} \times 20 \text{ ft} = 160 \text{ in-ft}$

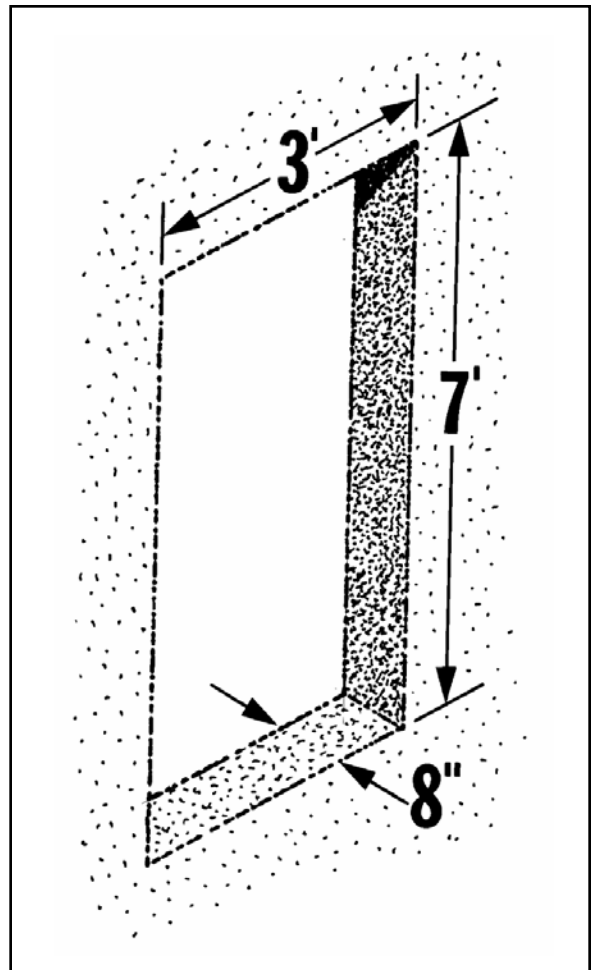





# 680GC OPERATOR'S MANUAL

**ICS, Blount Inc.**  
**4909 SE International Way**  
**Portland, OR 97222**  
**Tel 800-321-1240 Fax 503-653-4393**  
**[icsbestway.com](http://icsbestway.com)**